

Decoding RSSI Compression in RFID: Dynamic RCS Modeling and Tag-Intrinsic Power Metrics for Reliable Backscatter Networks

J. Liu, Y. Ma, X. Chen, H. Dai, H. Huang, **Z. Lin**, W. Zheng, J. Du, G. Chen



南京大學
NANJING UNIVERSITY



Soochow
University



西安電子科技大學
XIDIAN UNIVERSITY

RSSI: The Primary Metric for RFID Systems

Reader

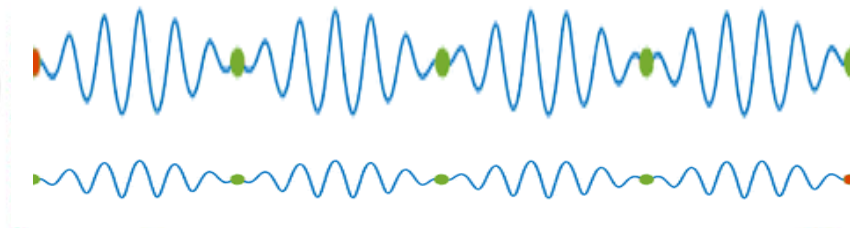
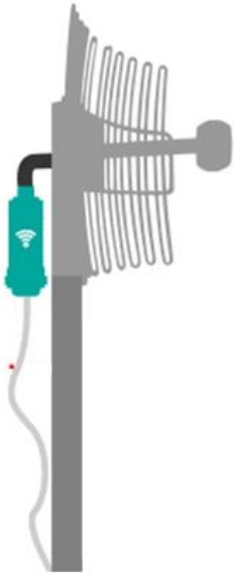

Amplitude

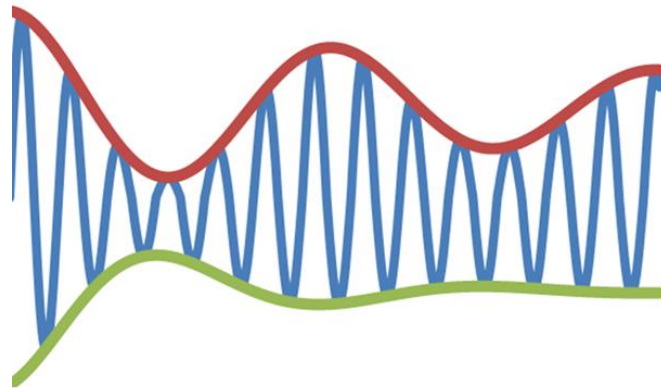

Received Signal Strength Indication (RSSI)

Tag

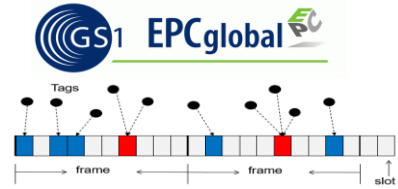

Communication

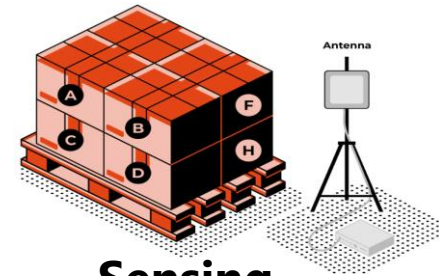

Sensing



Localization

RSSI Model: Transmit Power



Round-trip RFID Backscatter Link

Friis Equation (Round-trip Link):

$$P_{rx} = P_{tx} \cdot G^2_{reader} \cdot G^2_{tag} \cdot T_b \cdot \left(\frac{\lambda}{4\pi r}\right)^4$$
$$= P_{tx} \cdot C \quad (\text{at a fixed distance } r)$$



$$RSSI = P_{rx}^{[dBm]} = P_{tx}^{[dBm]} + C^{[dB]}$$



RSSI (in dBm) **scales linearly with** transmit power (in dBm)

RSSI Model: Distance



Round-trip RFID Backscatter Link

Friis Equation (Round-trip Link):

$$P_{rx} = P_{tx} \cdot G^2_{reader} \cdot G^2_{tag} \cdot T_b \cdot \left(\frac{\lambda}{4\pi r}\right)^4$$



$$RSSI \rightarrow P_{rx} \propto \left(\frac{1}{r}\right)^4$$



The distance **doubles**,
RSSI decreases by **12 dB**

RSSI Compression

$P_{tx} + 10 \text{ dB}$: $RSSI + 10 \text{ dB}$ \rightarrow $RSSI + 4.3 \text{ dB}$

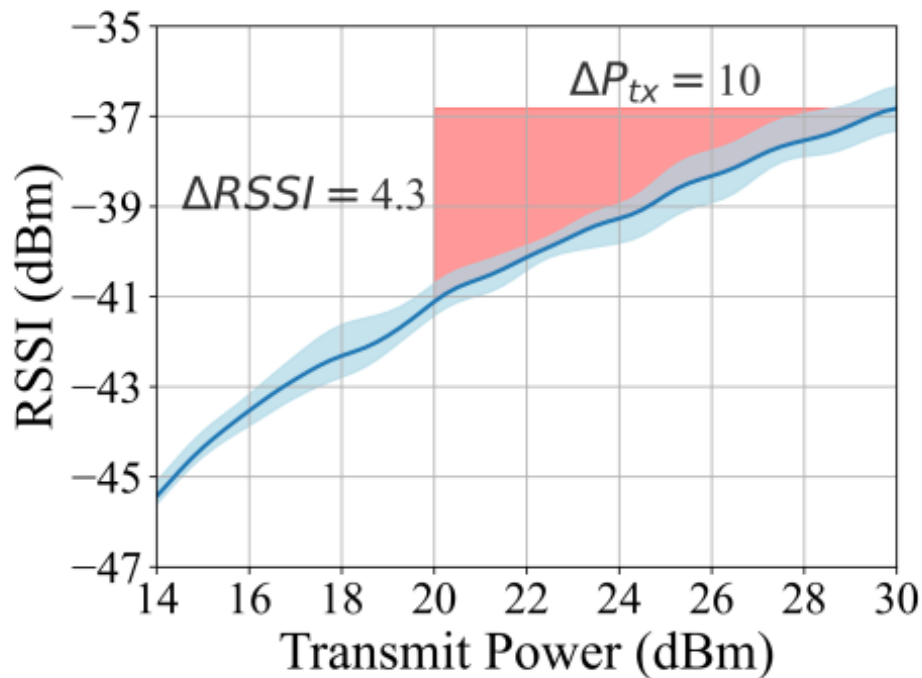

$$RSSI = P_{rx}^{[dBm]} = P_{tx}^{[dBm]} + C^{[dB]}$$

$r \times 2$: $RSSI - 12 \text{ dB}$ \rightarrow $RSSI - 6.8 \text{ dB}$

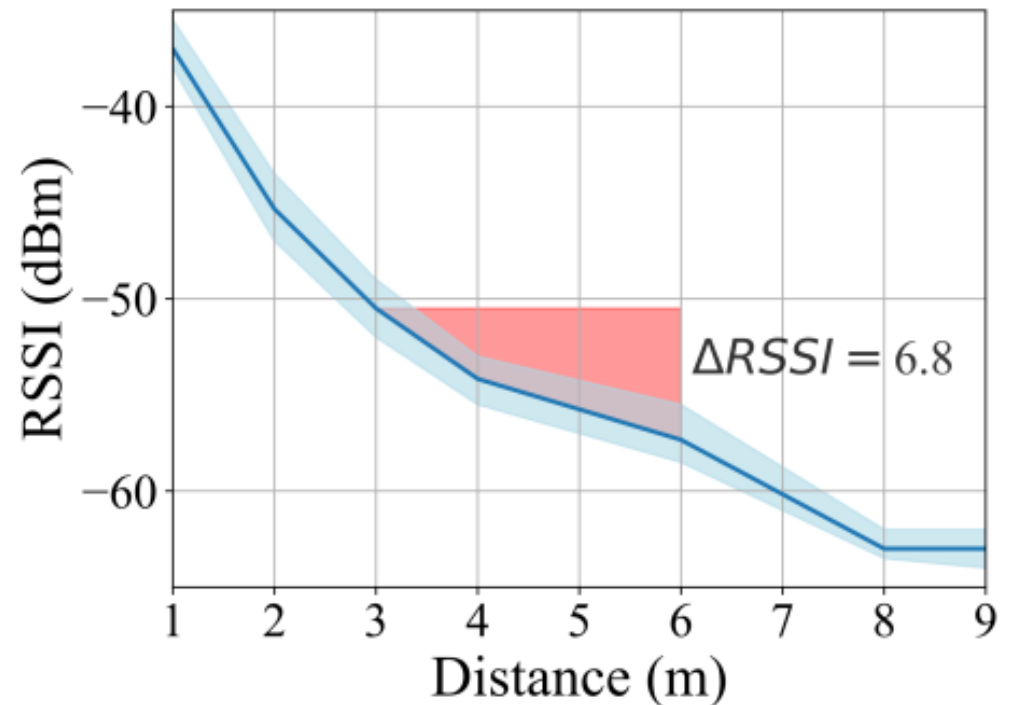

$$RSSI \rightarrow P_{rx} \propto \left(\frac{1}{r}\right)^4$$

RSSI Compression

$P_{tx} + 10 \text{ dB}$: $RSSI + 10 \text{ dB} \rightarrow RSSI + 4.3 \text{ dB}$

$r \times 2$: $RSSI - 12 \text{ dB} \rightarrow RSSI - 6.8 \text{ dB}$

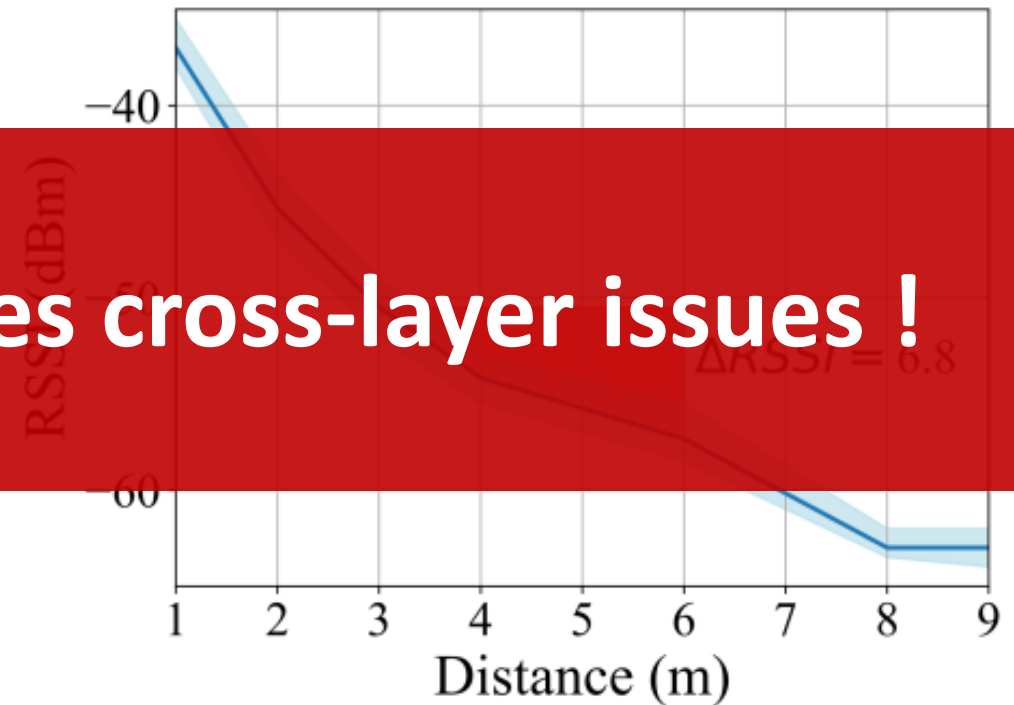
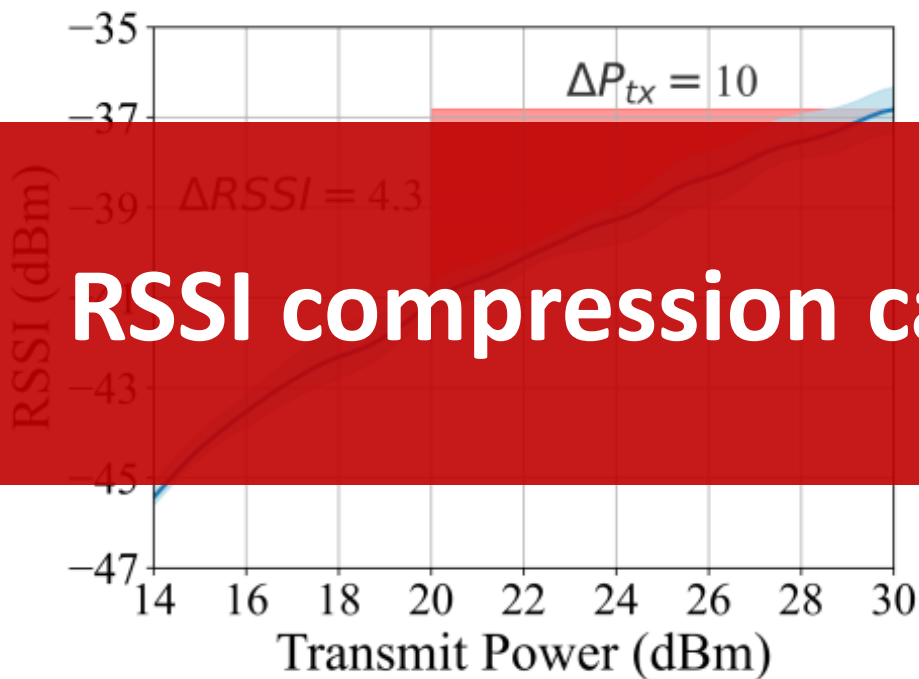

RSSI compression causes cross-layer issues !



$$RSSI = P_{rx}^{[dBm]} = P_{tx}^{[dBm]} + C^{[dB]}$$



$$RSSI \rightarrow P_{rx} \propto \left(\frac{1}{r}\right)^4$$

The Source of RSSI Compression

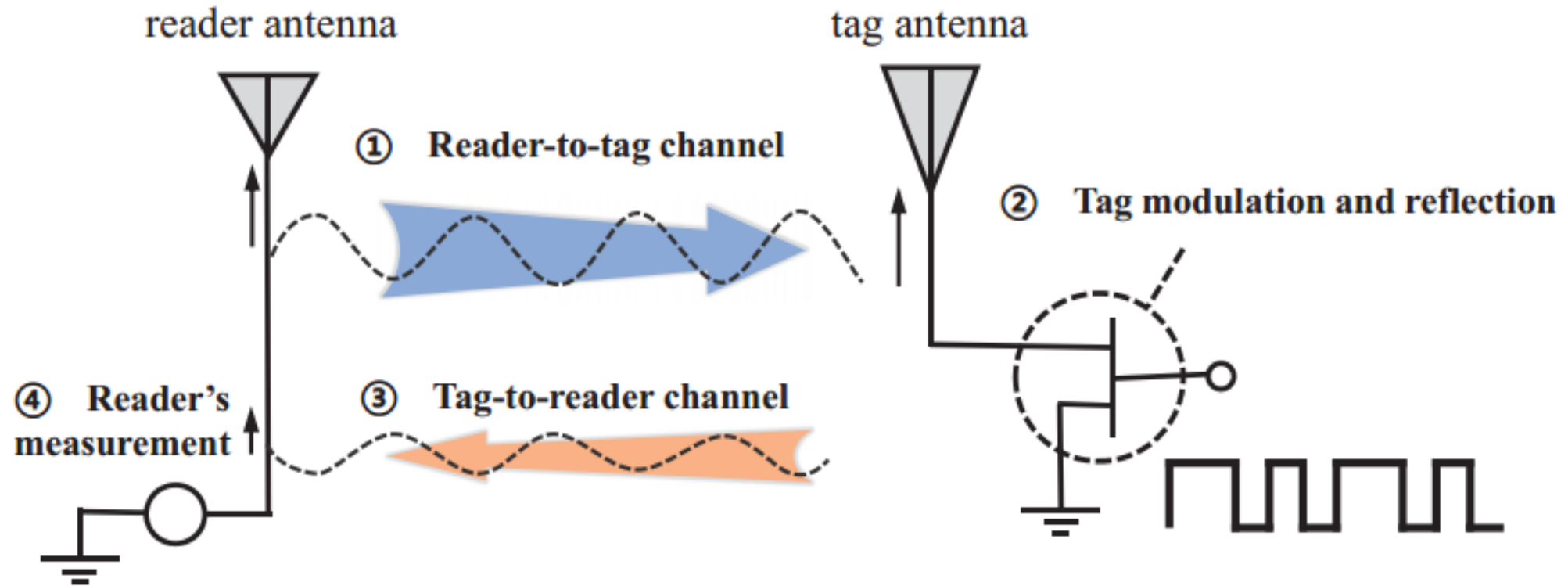

Four components in the round-trip backscatter communication.

The Source of RSSI Compression

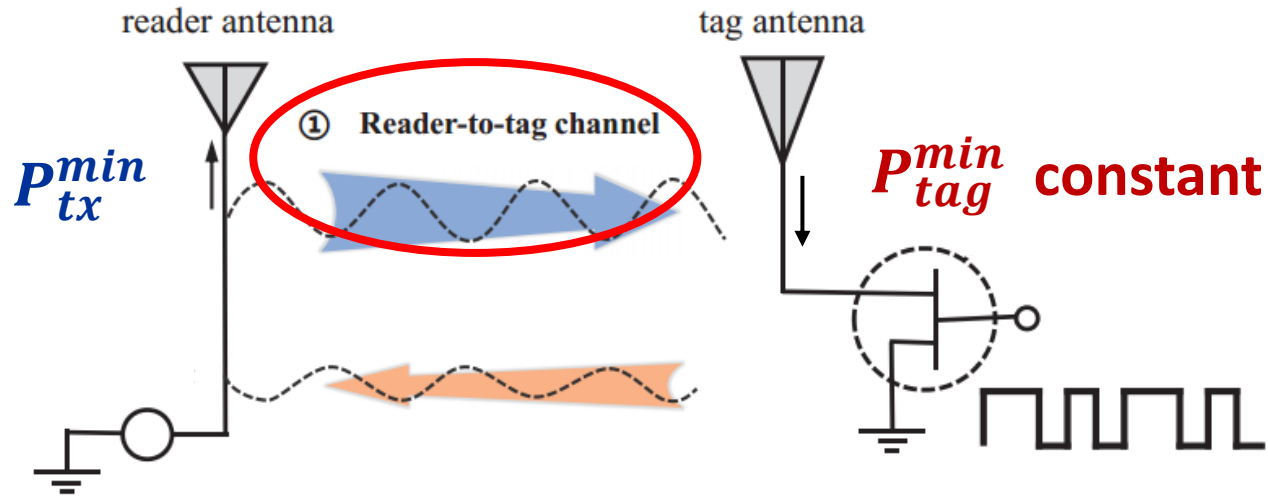

- Tag's activation power P_{tag}^{min} is constant
- Changing reader-to-tag distance
- Interrogation threshold power P_{tx}^{min}

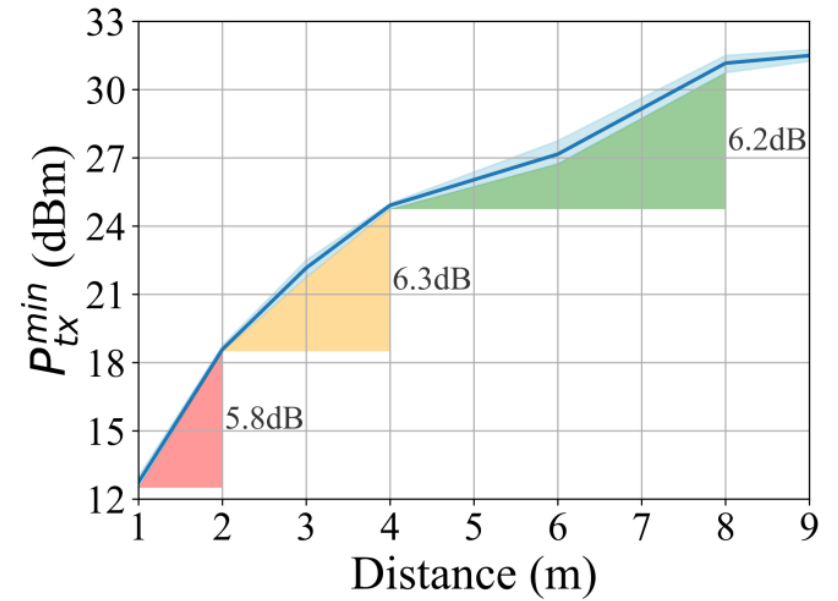

Not the source of RSSI Compression

The Source of RSSI Compression

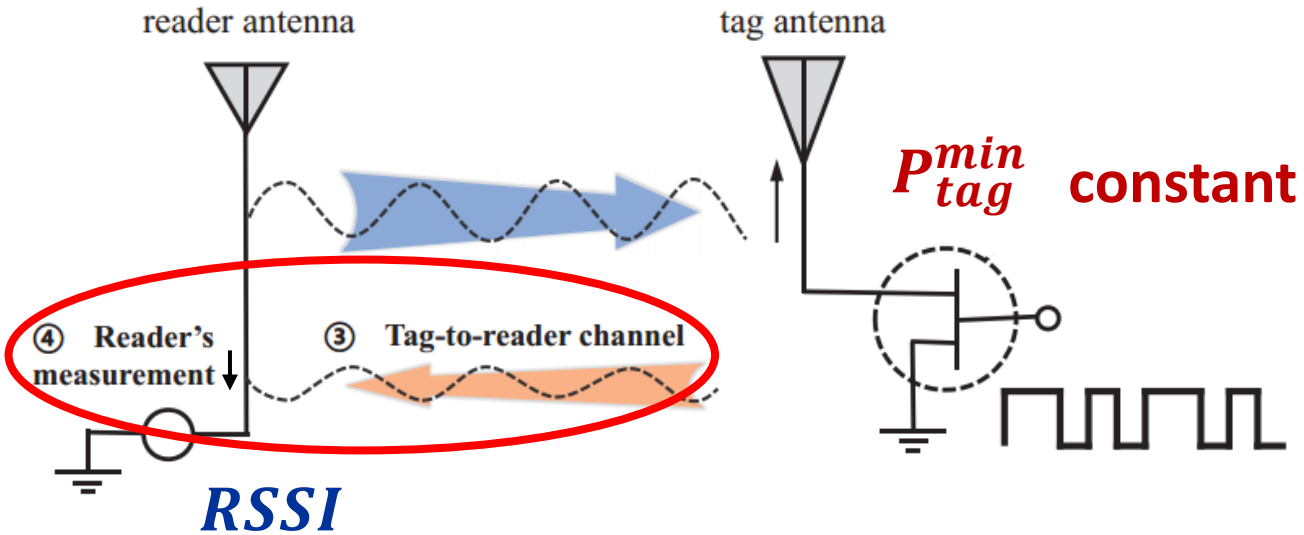

- Tag's activation power P_{tag}^{min} is constant
- Changing tag-to-reader distance
- Checking RSSI

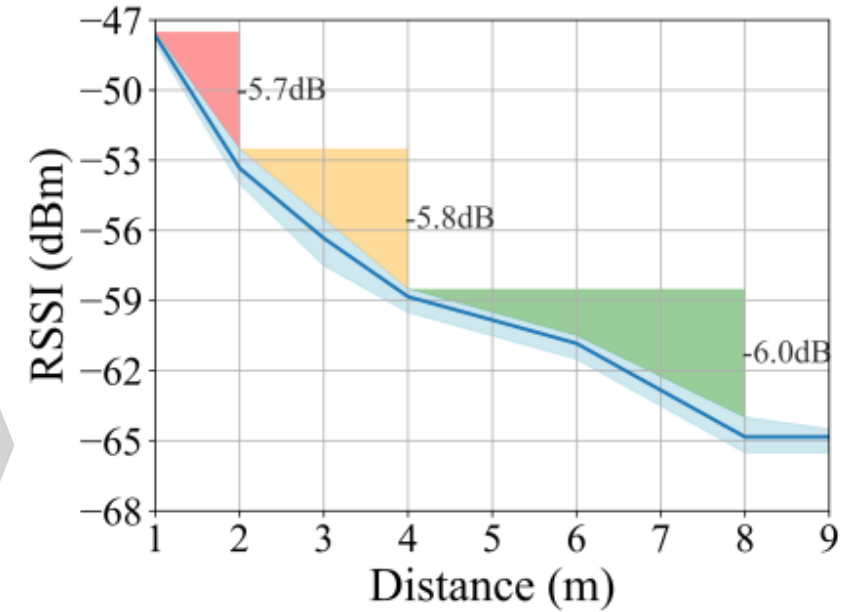

Not the source of RSSI Compression

The Source of RSSI Compression

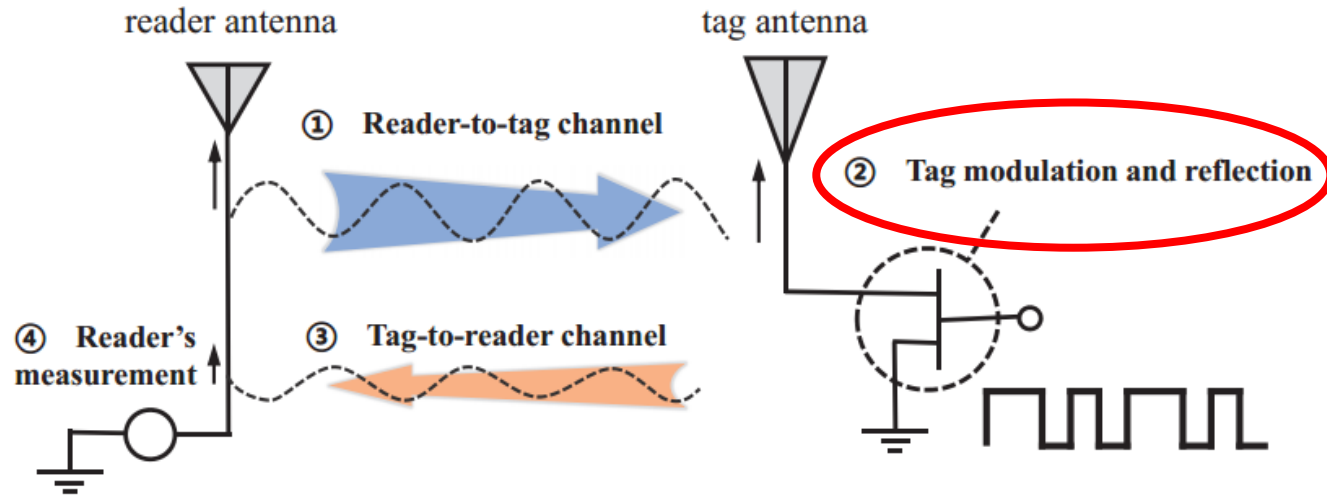

- **Three tag models (R6P, U8, H3)**
- **Varying transmit power**
- **Checking RSSI**

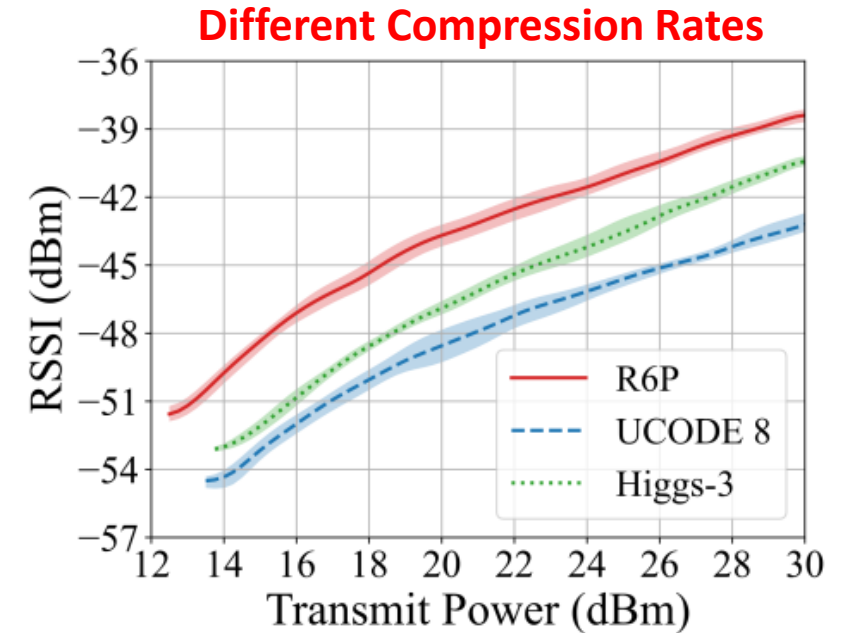

Cause of RSSI Compression

RSSI Compression: Dynamic RCS

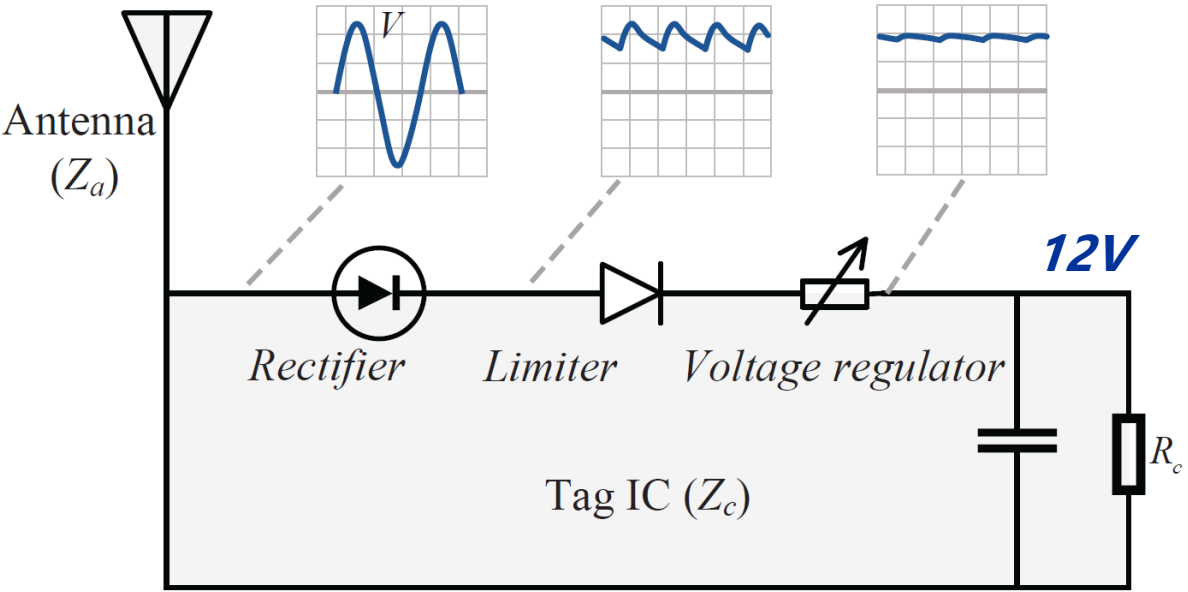

Rectification Process of RFID Tags

Radar Cross-Section (RCS)

$$\sigma = \left(\frac{\lambda^2}{4\pi} \right) G_{tag}^2 |1 - \Gamma|^2 = \frac{\lambda^2 G_{tag}^2 |Z_a|^2}{\pi |Z_c + Z_a|^2}$$

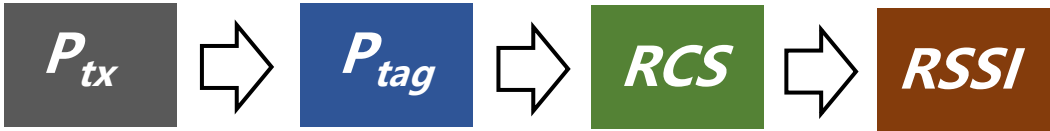

Dynamic RCS leads to non-linear

RSSI Correction: Direct Compensation

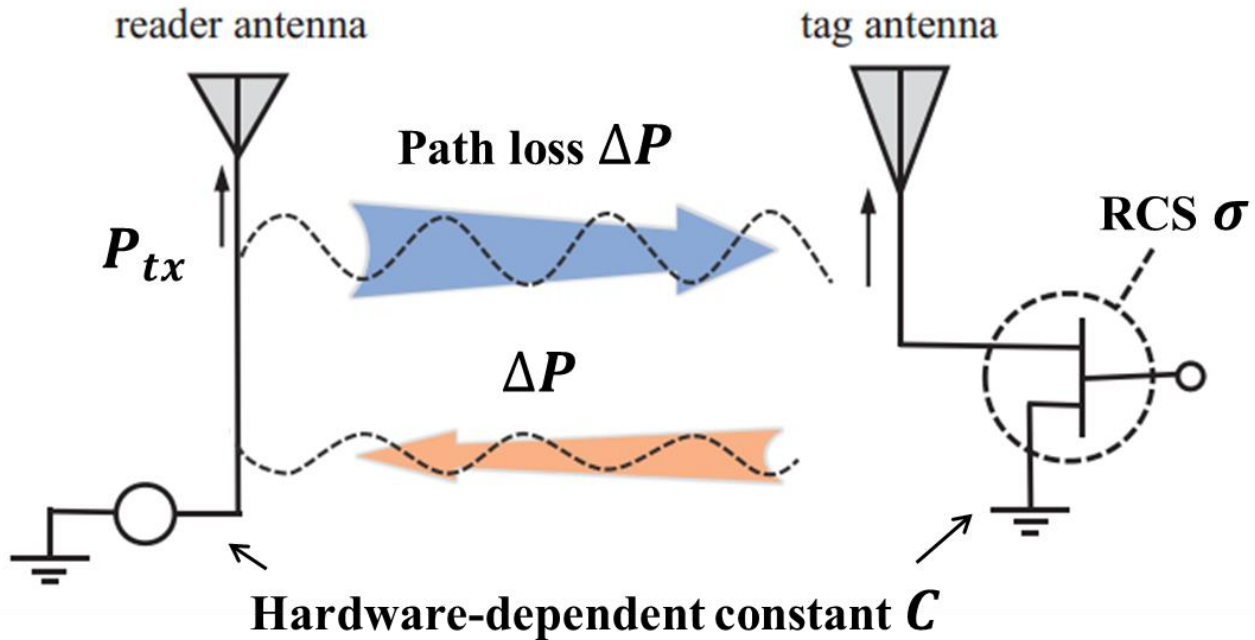

1. Pre-measure the reference RCS at a known distance and transmit power:

$$\sigma_{ref}^{[dB]}$$

$$RSSI = P_{tx}^{[dBm]} - 2\Delta P^{[dB]} + \sigma^{[dB]} + C$$

RSSI Correction: Direct Compensation

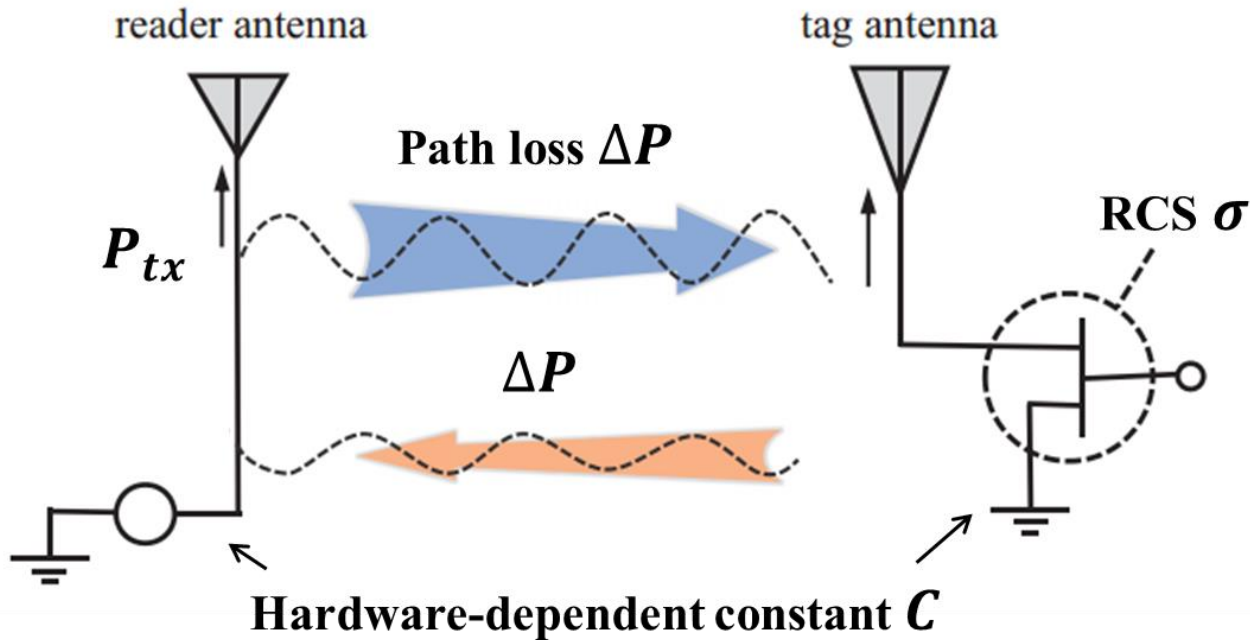

1. Pre-measure the reference RCS at a known distance and transmit power:

$$\sigma_{ref}^{[dB]}$$

2. Calculate the deviation based on the current power, distance, and RSSI:

$$\Delta\sigma^{[dB]} = \sigma_{ref}^{[dB]} - \sigma^{[dB]}$$

$$RSSI = P_{tx}^{[dBm]} - 2\Delta P^{[dB]} + \sigma^{[dB]} + C$$

RSSI Correction: Direct Compensation

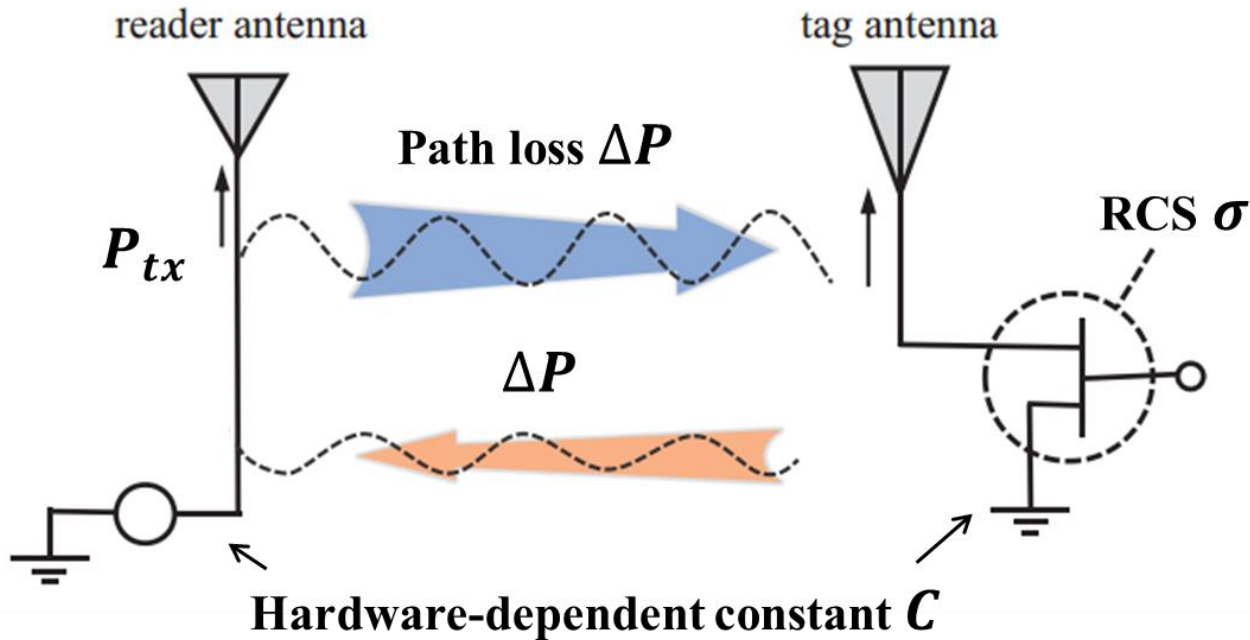

$$RSSI = P_{tx}^{[dBm]} - 2\Delta P^{[dB]} + \sigma^{[dB]} + C$$

1. Pre-measure the reference RCS at a known distance and transmit power:

$$\sigma_{ref}^{[dB]}$$

2. Calculate the deviation based on the current power, distance, and RSSI:

$$\Delta\sigma^{[dB]} = \sigma_{ref}^{[dB]} - \sigma^{[dB]}$$

3. Compensate for the non-linear effect of dynamic RCS:

$$RSSI_{fix} = RSSI + \Delta\sigma^{[dB]}$$

RSSI Correction: Direct Compensation

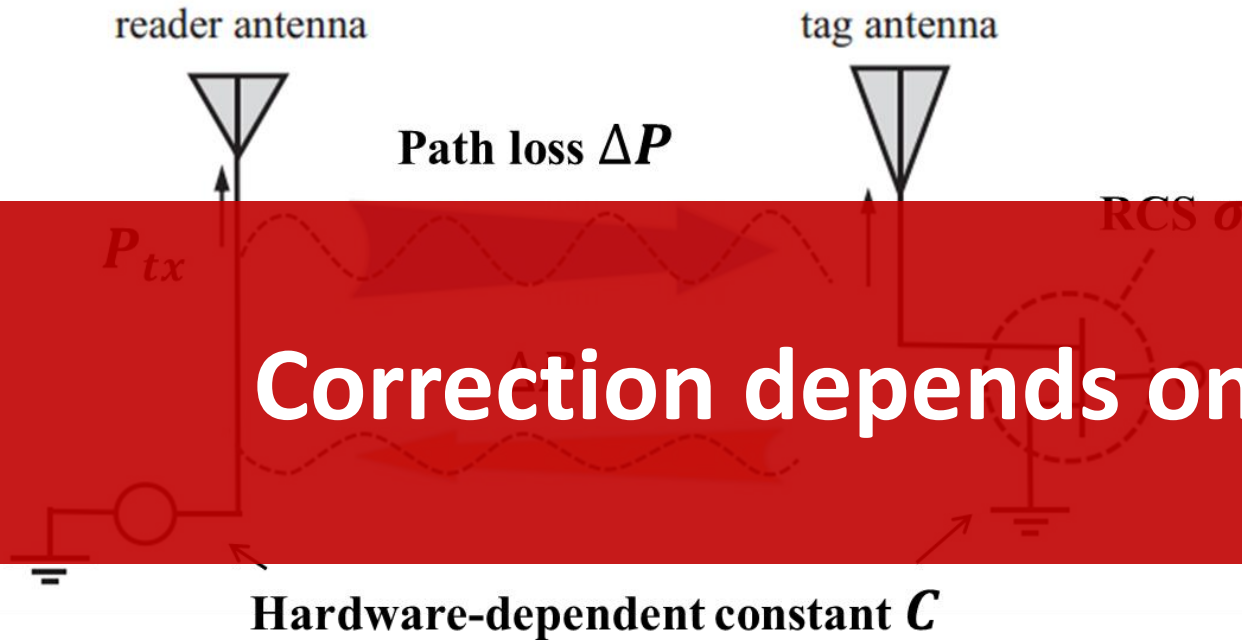

Correction depends on unknown distance!

$$RSSI = P_{tx}^{[dBm]} - 2\Delta P^{[dB]} + \sigma^{[dB]} + C$$

1. Pre-measure the reference RCS at a known distance and transmit power:

$$\sigma_{ref}^{[dB]}$$

2. Calculate the deviation based on the current power, distance, and RSSI:

$$\Delta\sigma^{[dB]} = \sigma_{ref}^{[dB]} - \sigma^{[dB]}$$

3. Compensate for the nonlinear effect of dynamic RCS:

$$RSSI_{fix} = RSSI + \Delta\sigma^{[dB]}$$

New Metric: ITP

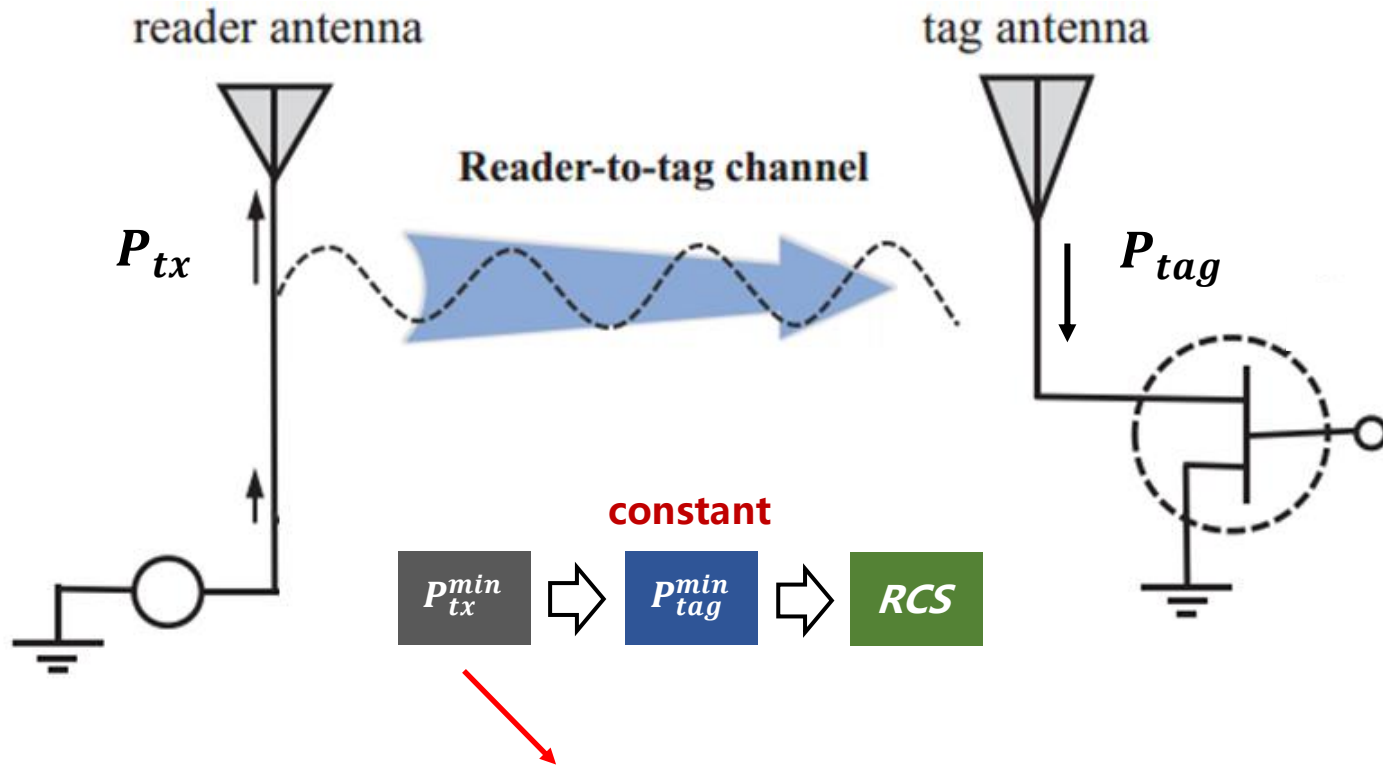

ITP: Interrogation Threshold Power

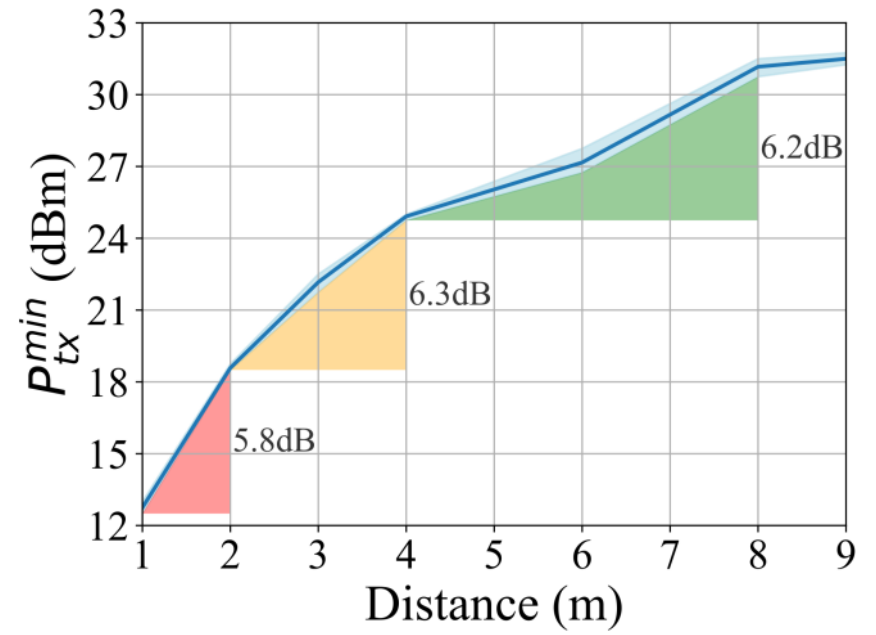

ITP: Reflect the link status

ITP Measurement: Power Sweep

Low P_{tx}



1. Begin with a low transmit power.

ITP Measurement: Power Sweep

Increase P_{tx}



1. Begin with a **low transmit power**.

2. **Increase** it until the tag responds

ITP Measurement: Power Sweep

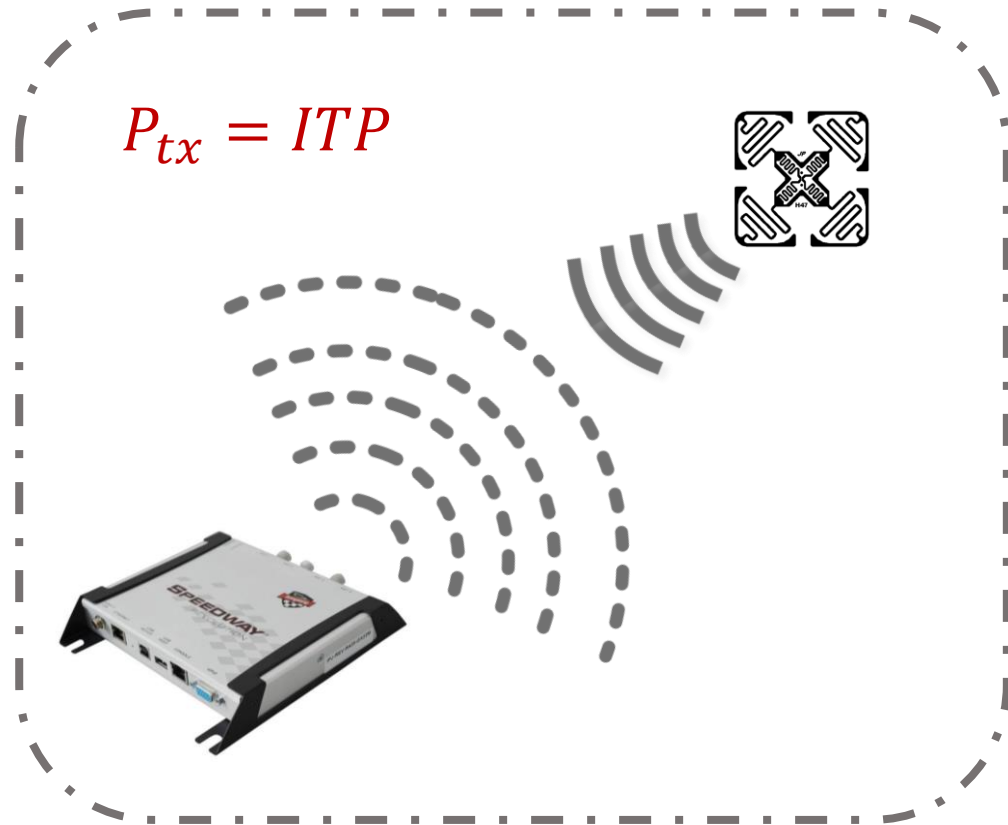

1. Begin with a **low transmit power**.

2. **Increase** it until the tag responds

3. The power that activates the **tag at the first time**

ITP Measurement: Power Sweep

$$P_{tx} = ITP$$



ITP: Power sweep measurement is slow.



1. Begin with a low transmit power.

2. Increase power until the tag responds

3. The power that activates the tag at the first time

BPI and In-situ Measurement

Decoupling RSSI via Tag Received Power (P_{tag})

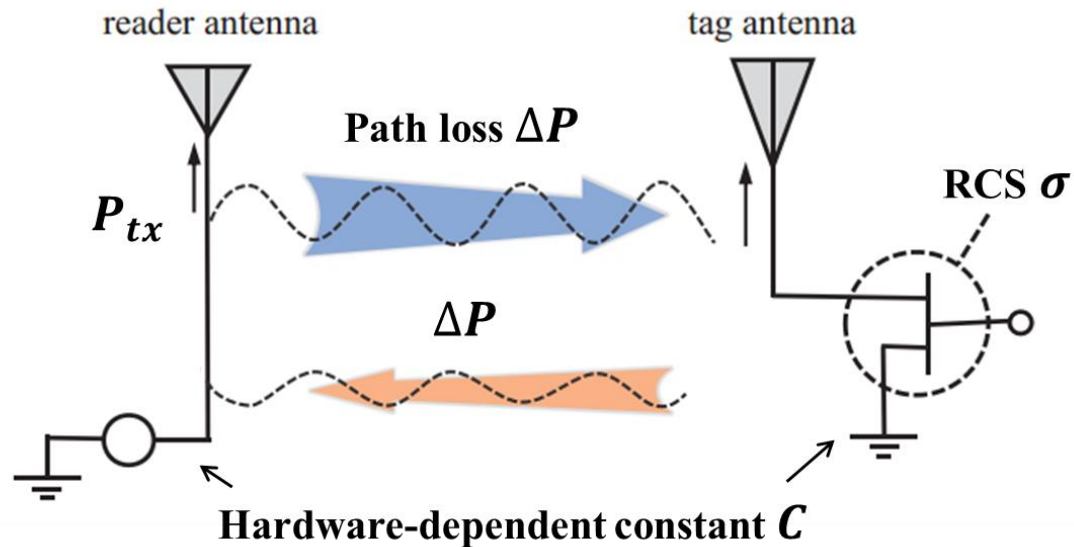

$$RSSI = P_{tx}^{[dBm]} - 2\Delta P^{[dB]} + \sigma^{[dB]} + C$$

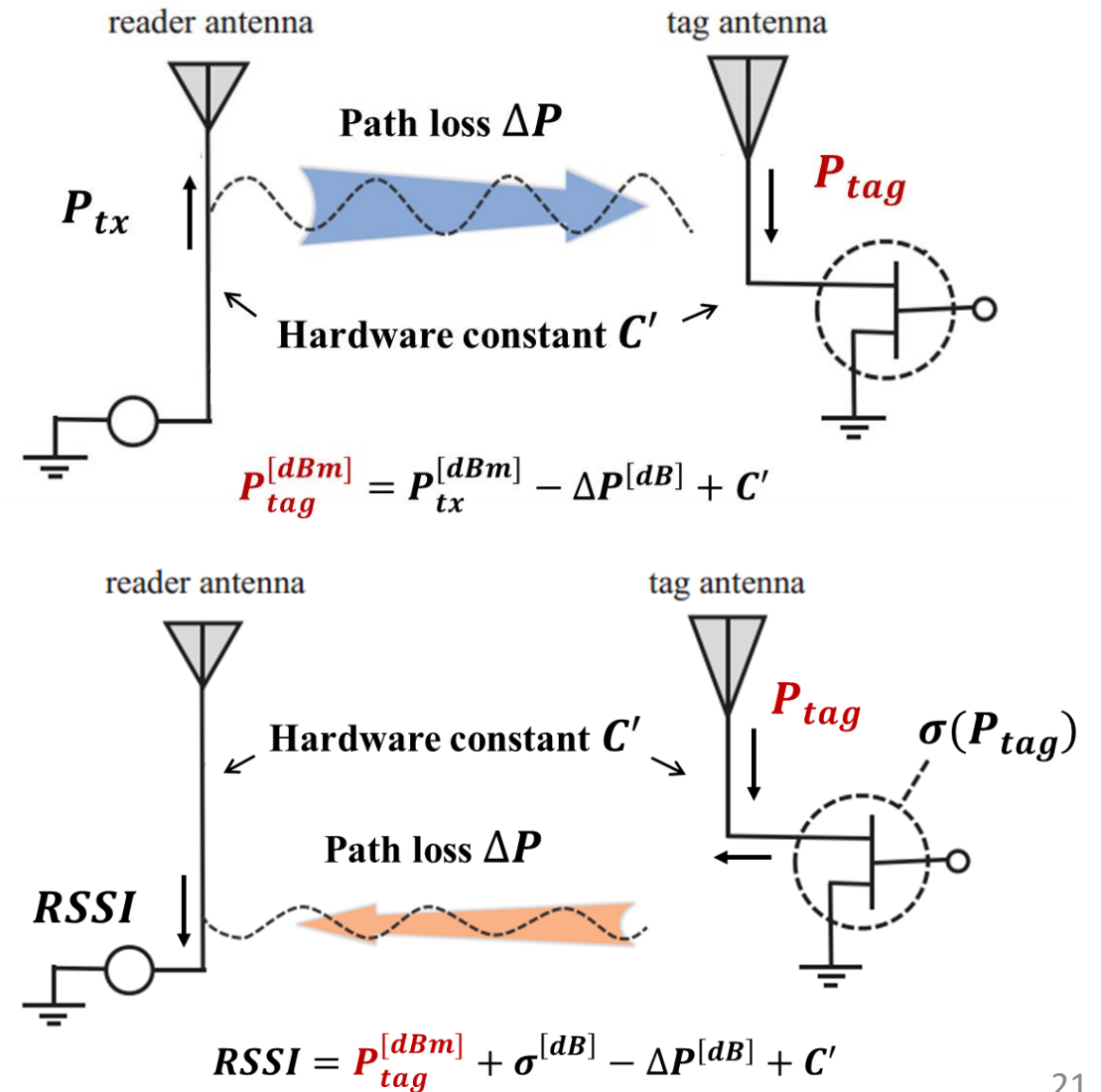

BPI and In-situ Measurement

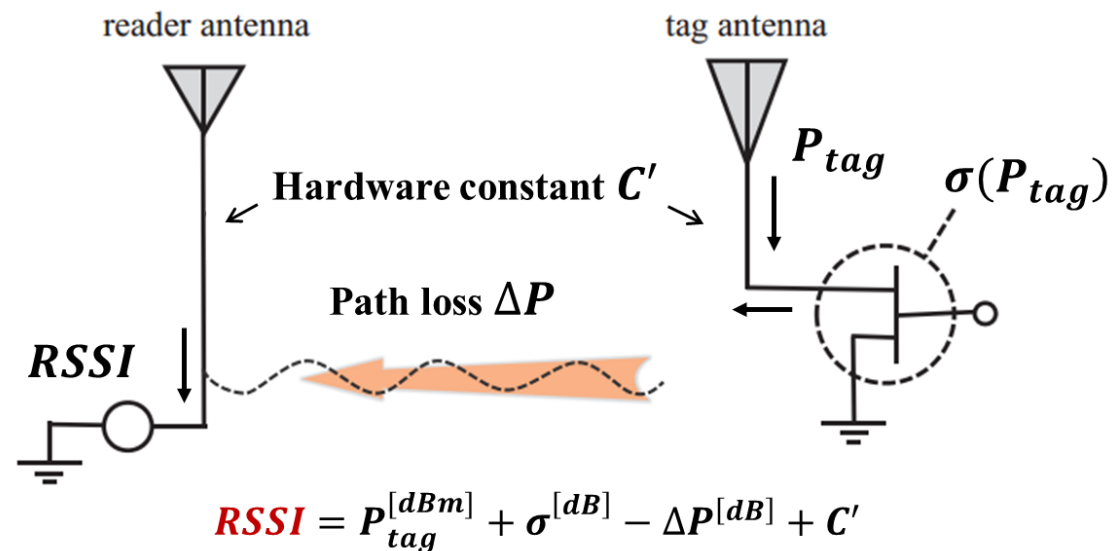
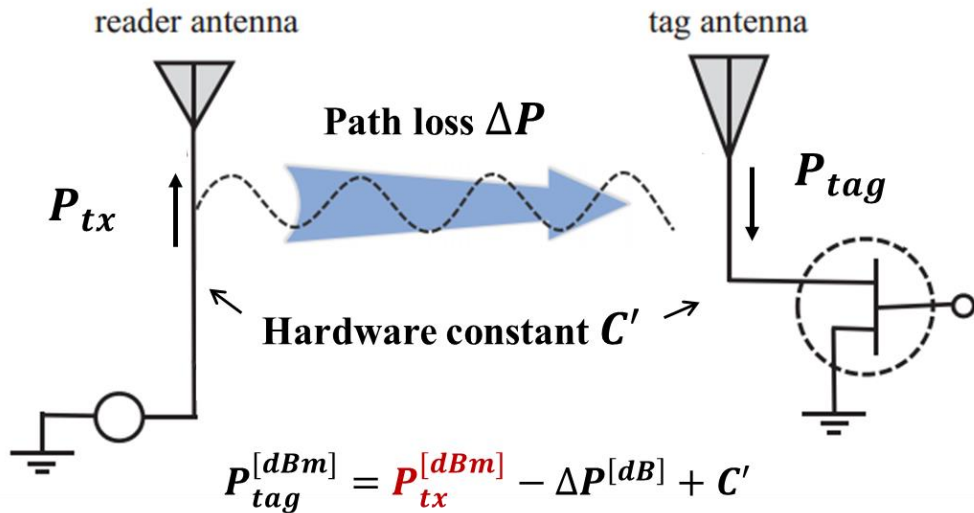

Backscatter Power Index (BPI):

$$\begin{aligned} h(\chi) &= -RSSI - P_{tx}^{[dBm]} \\ &= -2P_{tag}^{[dBm]} + \sigma(P_{tag})^{[dB]} \\ &= -2(P_{tag}^{min} + \chi) + \sigma(P_{tag}^{min} + \chi) \end{aligned}$$



Distance-related ΔP is removed

BPI and In-situ Measurement

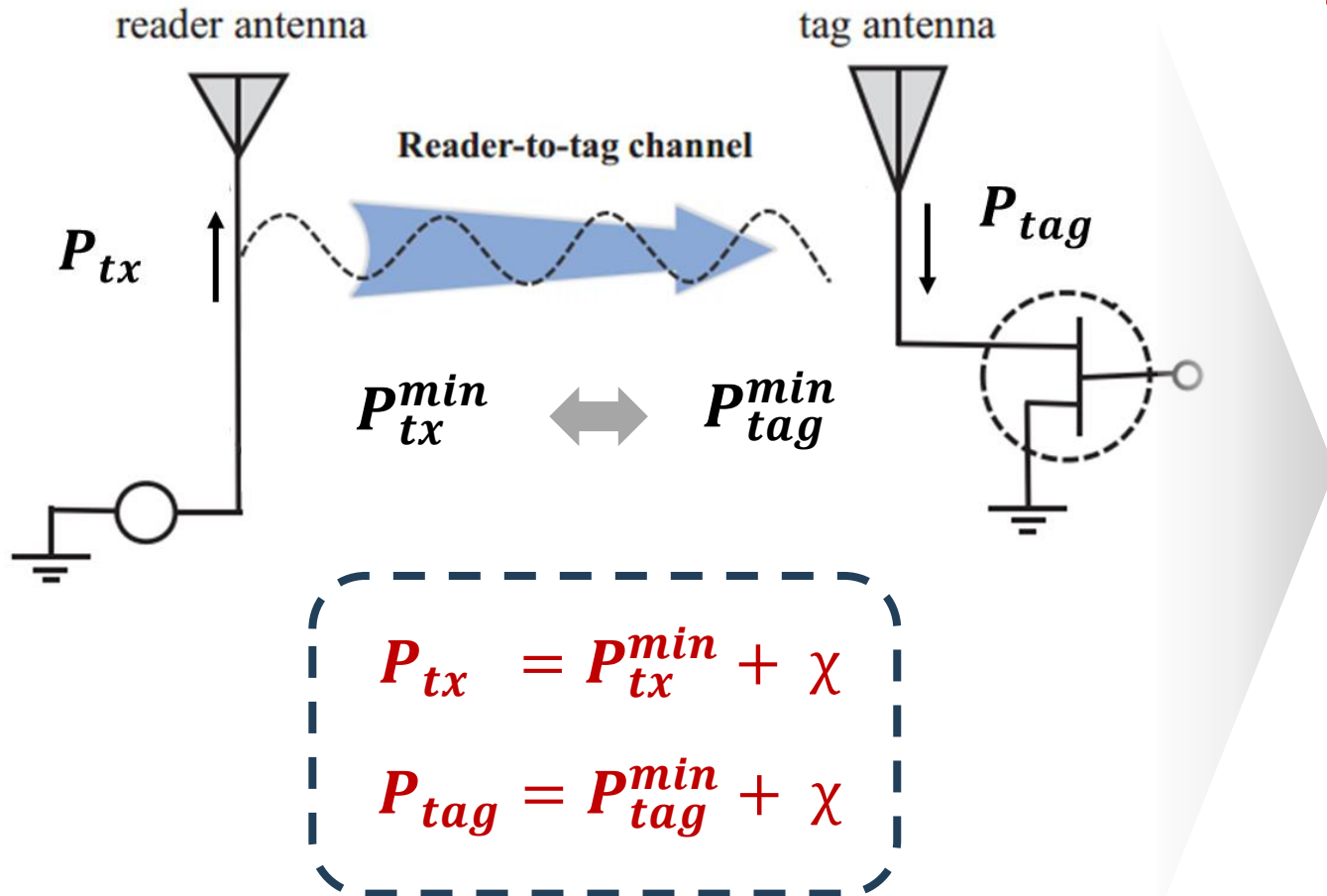

Backscatter Power Index (BPI):

$$\begin{aligned}
 h(\chi) &= -RSSI - P_{tx}^{[dBm]} \\
 &= -2P_{tag}^{[dBm]} + \sigma(P_{tag})^{[dB]} \\
 &= -2(P_{tag}^{min} + \chi) + \sigma(P_{tag}^{min} + \chi)
 \end{aligned}$$

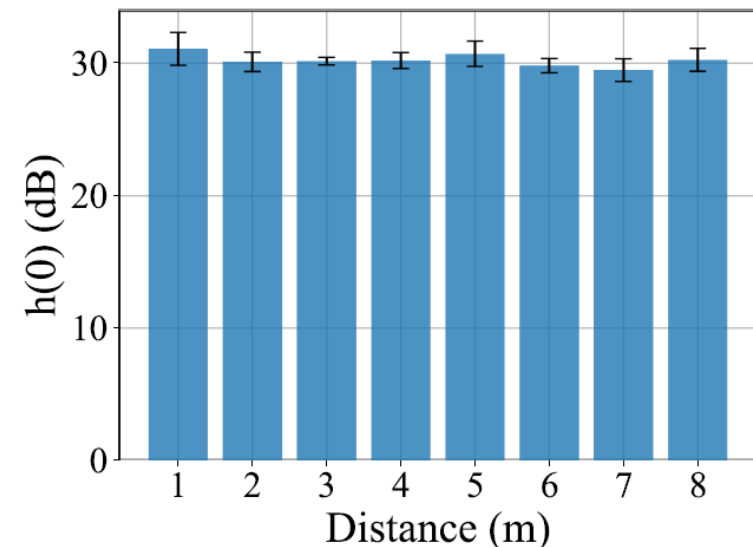

BPI and In-situ Measurement

1. Build a lookup table mapping $h(\chi)$ and χ .

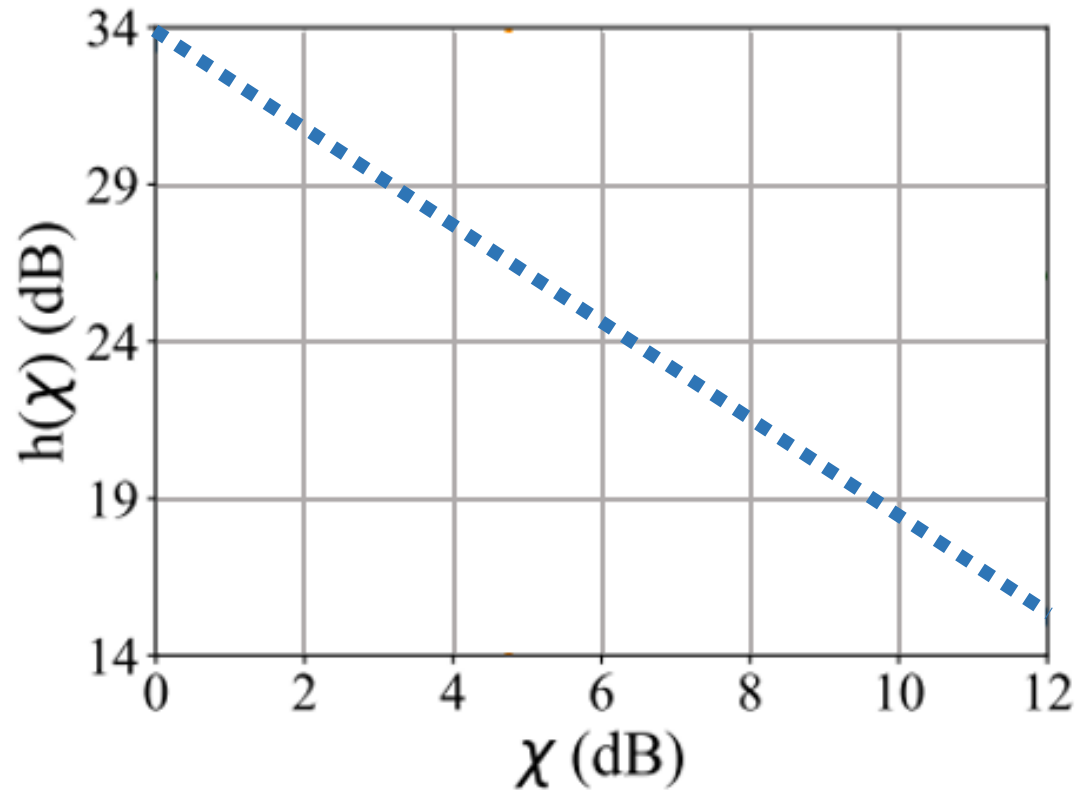

BPI and In-situ Measurement

Assuming $P_{tx} = 24\text{dBm}$, $RSSI = -50\text{dBm}$

Calculate $h(\chi) = -RSSI - P_{tx} = 26$

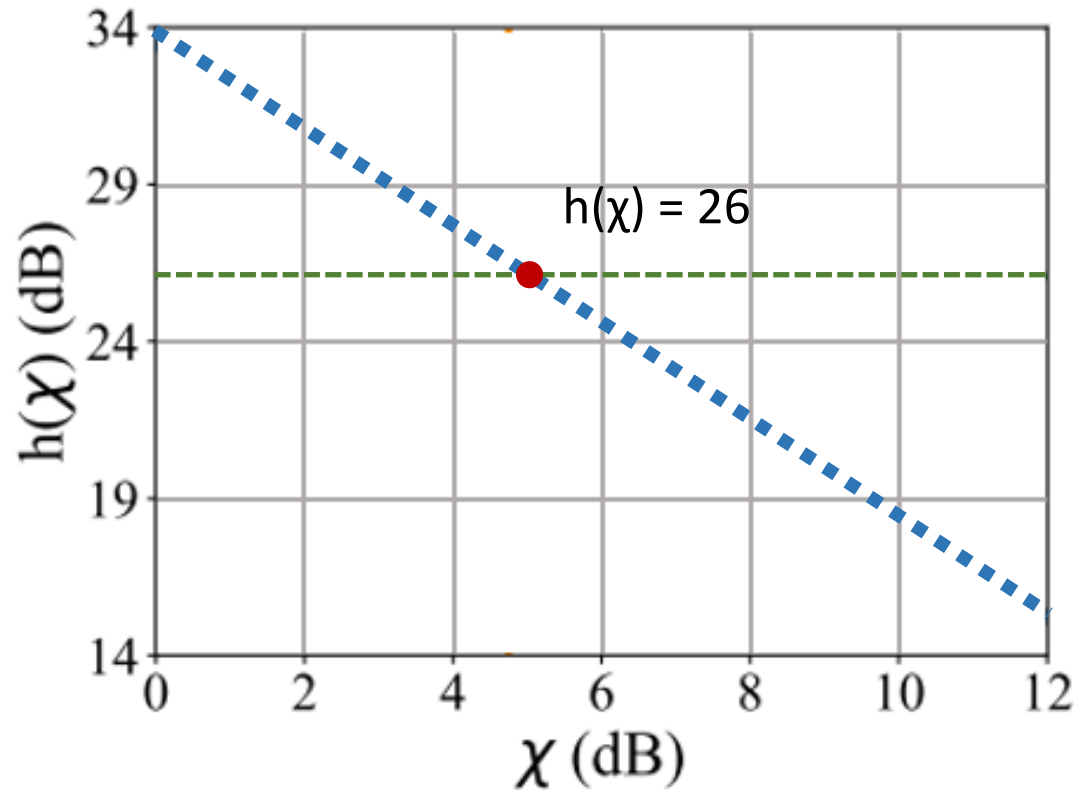

1. Build a lookup table mapping $h(\chi)$ and χ .

2. Measure RSSI, calculate $h(\chi)$.

BPI and In-situ Measurement

From the lookup table, we can find $\chi = 4.75$

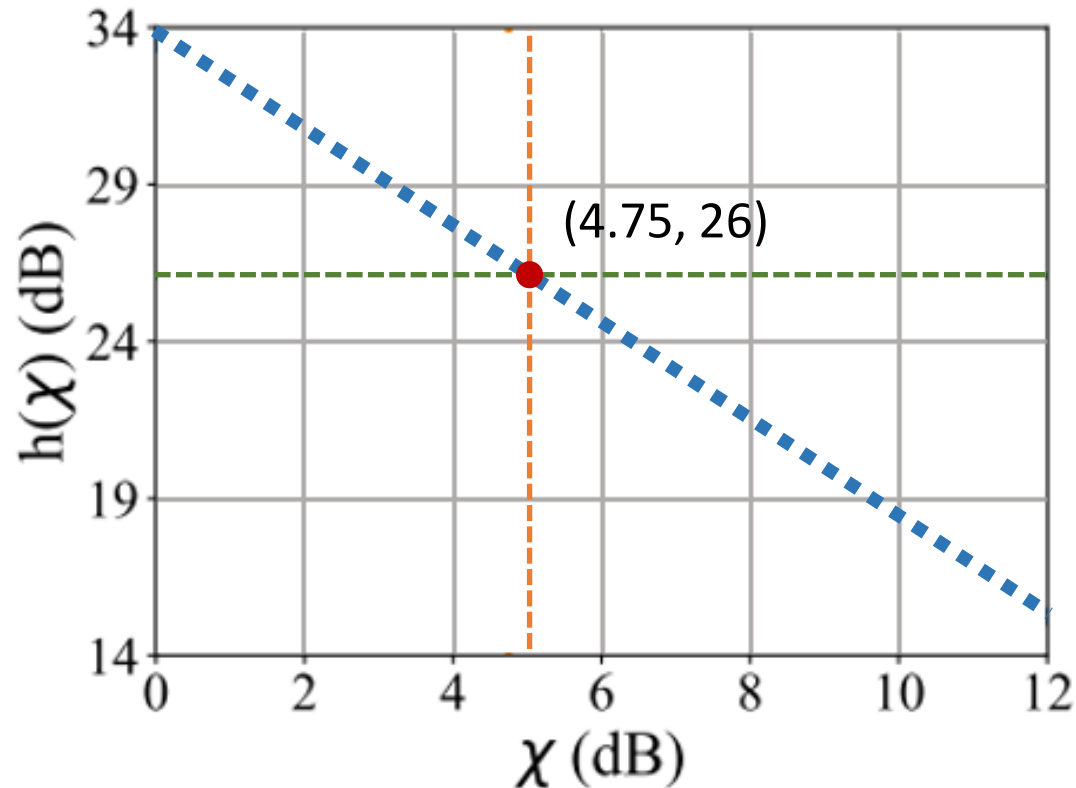

1. Build a lookup table mapping $h(\chi)$ and χ .

2. Measure RSSI, calculate $h(\chi)$.

3. Retrieve χ according to the lookup table

BPI and In-situ Measurement

Calculate $P_{tx}^{min} = P_{tx} - \chi = 24 - 4.75 = 19.25$

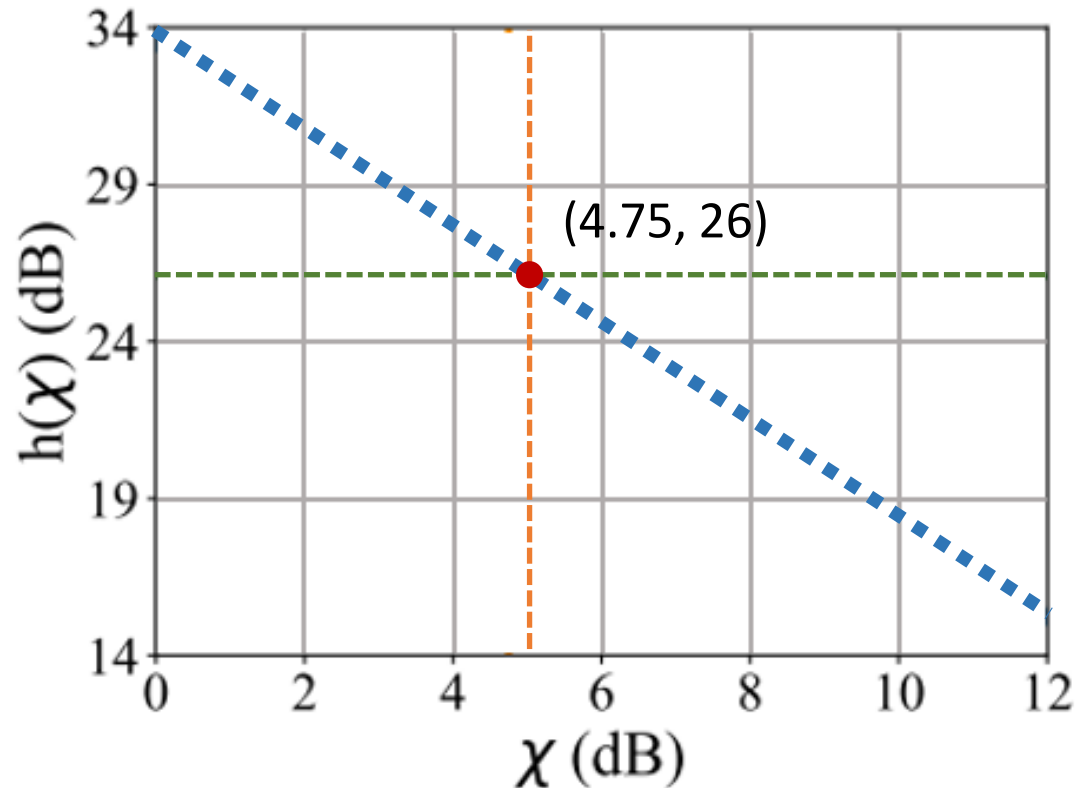

1. Build a lookup table mapping $h(\chi)$ and χ .

2. Measure RSSI, calculate $h(\chi)$.

3. Retrieve χ according to the lookup table

4. $P_{tx}^{min} = P_{tx} - \chi$

BPI and In-situ Measurement

Calculate $P_{tx}^{min} = P_{tx} - \chi = 24 - 4.75 = 19.25$

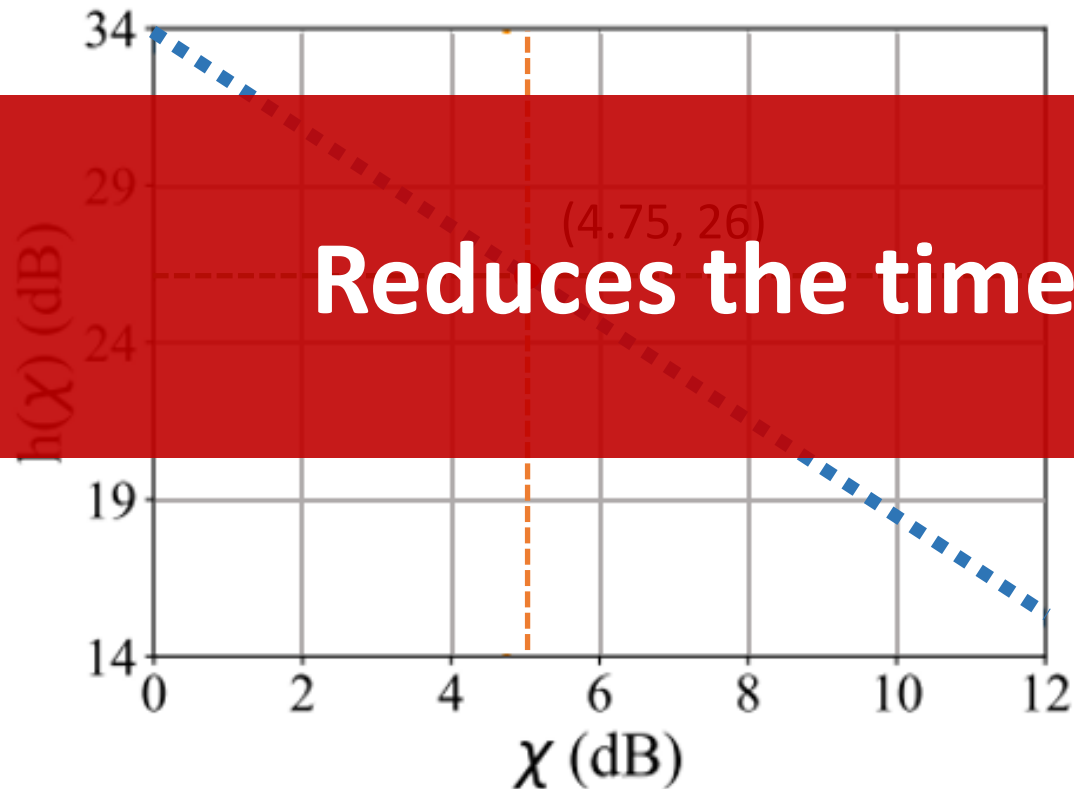

Reduces the time overhead by 99.8%

1. Build a lookup table mapping $h(\chi)$ and χ .

2. Measure RSSI, calculate $h(\chi)$.

3. Retrieve χ according to the lookup table

4. $P_{tx}^{min} = P_{tx} - \chi$

Experimental Setup



RFID readers and tags

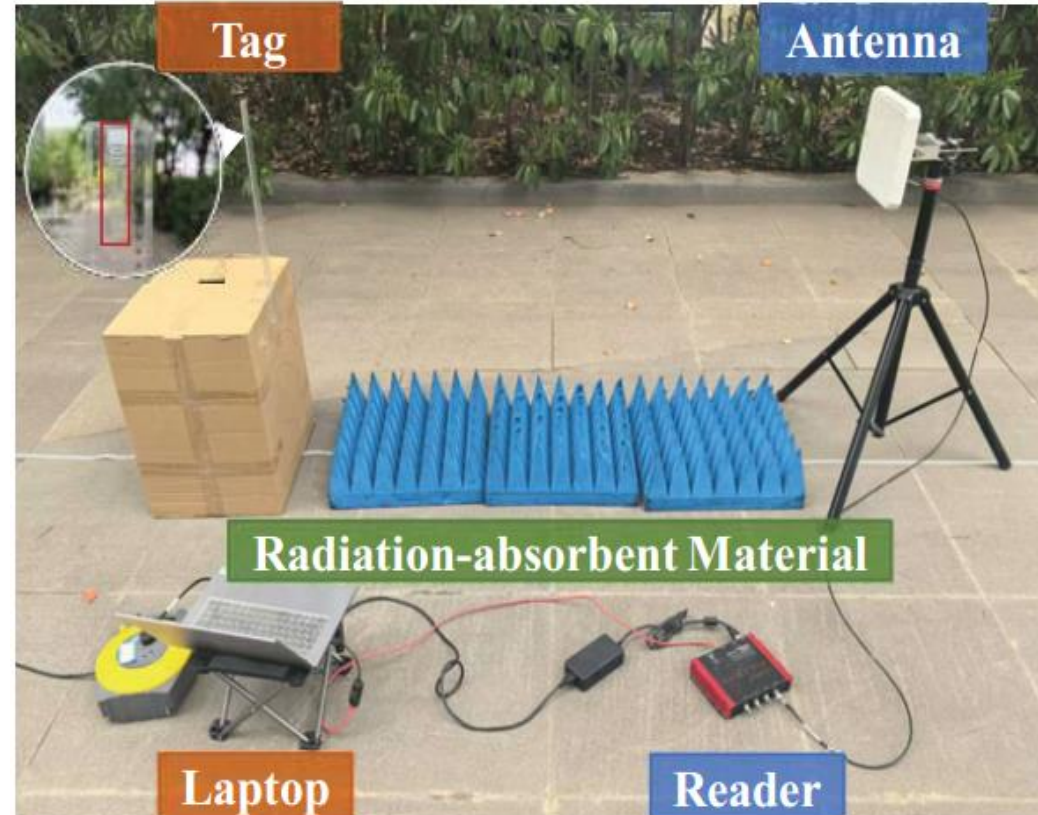

System deployments

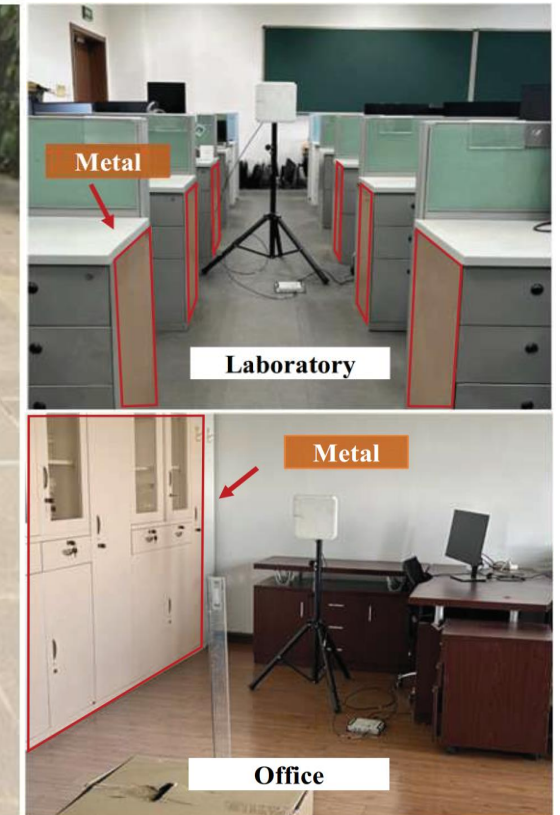

Evaluation: Robustness of BPI

BPI exhibits strong robustness to distance under fixed excess power χ .

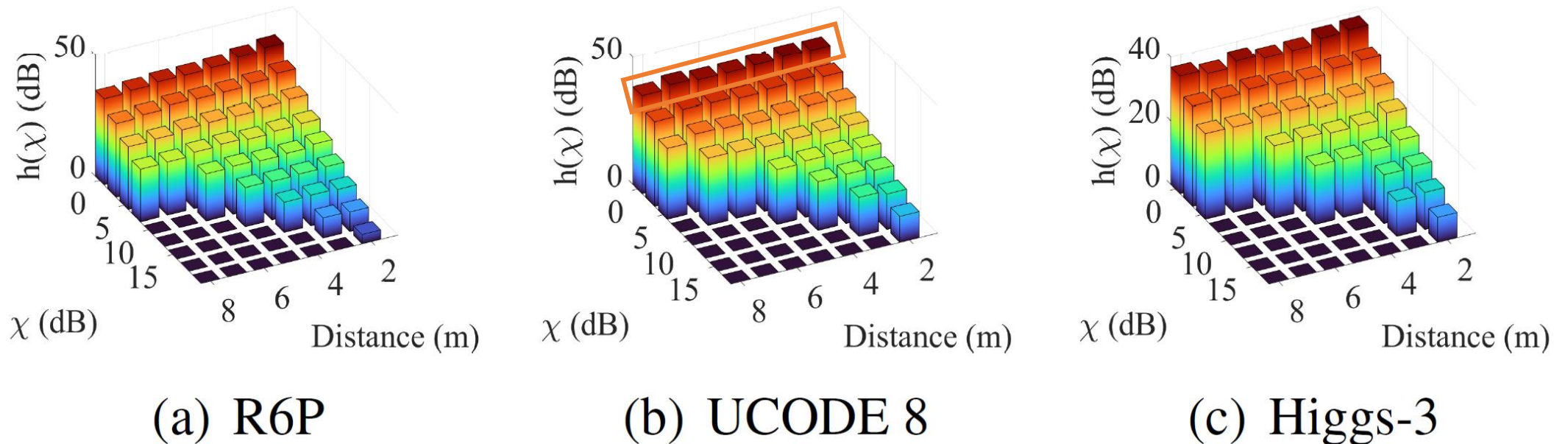

Figure 1: BPI against excess power χ across different distances.

Evaluation: Robustness of BPI

BPI depends solely on the tag's RCS and is independent of the environment.

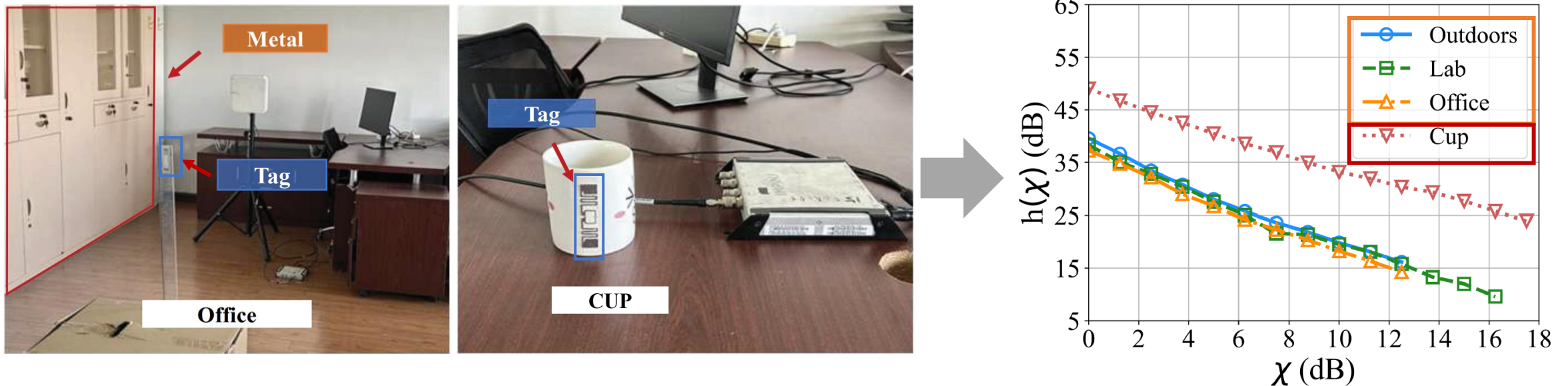

Figure 2: Variation of BPI with χ across scenarios and substrates

Evaluation: Performance of ITP

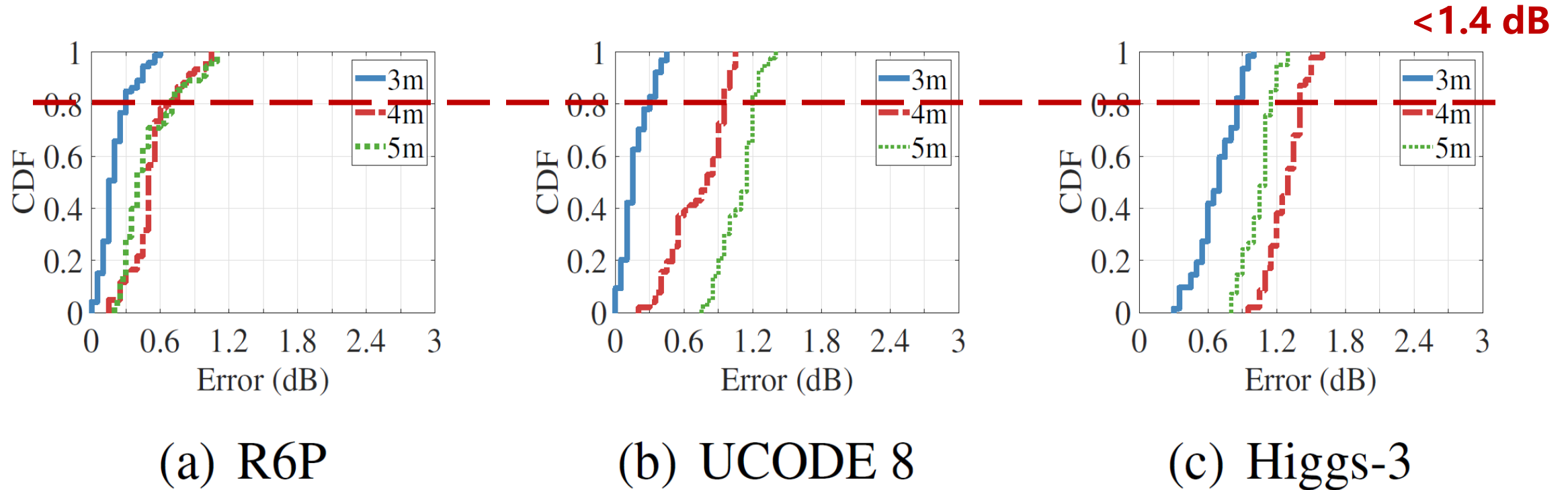

Figure 3: Accuracy of in-situ measurement.

Evaluation: Performance of ITP

The error is reduced by 64.7% compared to raw-RSSI methods

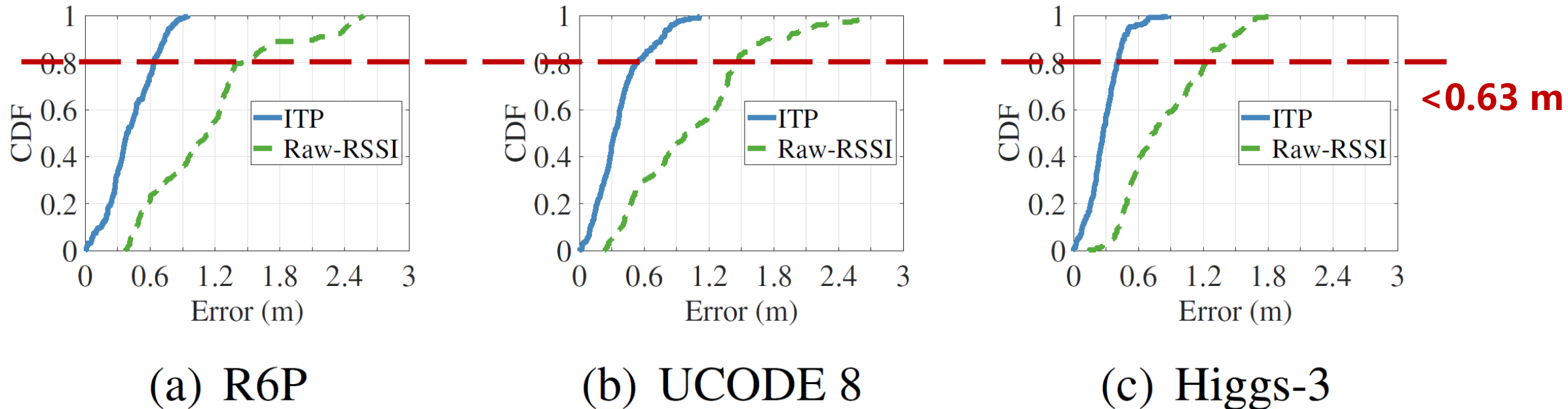

Figure 4: Accuracy of distance estimation.

Conclusion

01

We uncover and decode the RSSI Compression phenomenon, a critical issue in RFID systems, and trace it back to the dynamic RCS behavior of passive tags.

02

We introduce two metrics, ITP for accurate link estimation and BPI for environment-independent measurement, together with an efficient in-situ single-query method.

03

We evaluate our in-situ method across three commercial RFID systems. Experiments show that it significantly reduces time overhead and channel-estimation error.



Thank You

Email: jialiu@nju.edu.cn

誠樸確偉 勵學敦行